

**STATION POST**

CAT. NO. 17PA28

230 kV 900 kV BIL

TR. NO. 308

4 HOLES 5/8"-11 +.015  
ON 5" B.C.

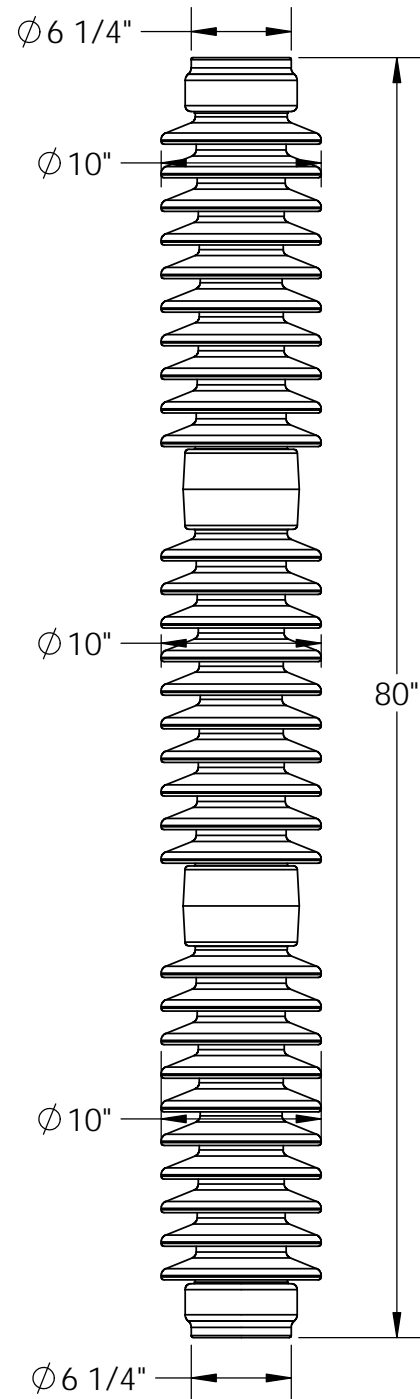

DIMENSIONS:

LEAKAGE DISTANCE IN 165

MECHANICAL VALUES:

CANTILEVER STRENGTH LB 1,450  
TENSION STRENGTH LB 25,000  
TORSION STRENGTH IN-LB 90,000  
COMPRESSION STRENGTH LB 75,000

ELECTRICAL VALUES:

IMPULSE FLASHOVER-POSITIVE kV 1,010  
60 HERTZ WITHSTAND-WET kV 385  
IMPULSE WITHSTAND kV 900

RADIO INFLUENCE VOLTAGE DATA:

60 HERTZ TEST VOLTAGE TO GROUND kV 146  
MAXIMUM R.I.V. @ 1000 kHz  $\mu$ V 500

PACKAGING INFORMATION:

NET WEIGHT, LB 307  
PACKED WEIGHT LB 347  
NO. IN STANDARD PACKAGE 1

- 1 ENG. MGR
- 2 ENG
- PURCH.
- 1 MKTG.
- PLT.MGR.
- COST
- PRD.
- INSP
- GLAZE
- BUSHING
- MAKING
- SHIP
- ASSEM
- MODEL
- MACH.
- 45
- TOOLING
- CER LAB
- 1 EL LAB
- 1 E.MEDIA

THIS DRAWING IS THE PROPERTY OF VICTOR INSULATORS, INC. AND CONTAINS PROPRIETARY AND CONFIDENTIAL INFORMATION WHICH MUST NOT BE DUPLICATED, USED, OR DISCLOSED OTHER THAN AS EXPRESSLY AUTHORIZED BY VICTOR INSULATORS, INC.

**APPROVED**

By A. E. Schwalm at 12:40 pm, Nov 10, 2015



**Victor Insulators, Inc.**

280 Maple Avenue  
Victor, New York 14564  
Telephone: (585)924-2127  
www.victorinsulators.com

**17PA28**

11-10-15

TM

SUPSEDES 17PA28 DATED 12-05-96